

定 格

# Z25M/Z33M

## 定 格

Z25M221S~102S

形 名	バリスタ電圧 V <sub>1mA</sub>		最大許容回路電圧		最大制限電圧 V <sub>150A</sub>	最大平均 パルス電力 W	エネルギー耐量 (2ms) J	サージ電流耐量 (8/20μs) A	静電容量(参考値) (1kHz) pF
	DC (V)		AC	DC	V				
	V <sub>rms</sub>	V	V	V					
Z25M221S	187.0~	253.0	120	165	380	1.0	125	10,000	3,300
Z25M271S	229.5~	310.5	150	210	465		155		2,200
Z25M331S	280.5~	379.5	175	245	570		185		1,900
Z25M391S	331.5~	448.5	210	295	675		215		1,700
Z25M441S	374.0~	506.0	240	335	760		225		1,500
Z25M471S	399.5~	540.5	250	350	810		235		1,500
Z25M561S	476.0~	644.0	300	420	970		260		1,400
Z25M681S	578.0~	782.0	365	510	1,175		280		1,250
Z25M821S	697.0~	943.0	440	615	1,415		330		800
Z25M102S	850.0~	1,150.0	520	730	1,725		375		500

Z33M221S~102S

形 名	バリスタ電圧 V <sub>1mA</sub>		最大許容回路電圧		最大制限電圧 V <sub>200A</sub>	最大平均 パルス電力 W	エネルギー耐量 (2ms) J	サージ電流耐量 (8/20μs) A	静電容量(参考値) (1kHz) pF
	DC (V)		AC	DC	V				
	V <sub>rms</sub>	V	V	V					
Z33M221S	187.0~	253.0	120	165	380	1.2	200	20,000	5,500
Z33M271S	229.5~	310.5	150	210	465		255		4,200
Z33M331S	280.5~	379.5	175	245	570		310		3,700
Z33M391S	331.5~	448.5	210	295	675		360		3,200
Z33M441S	374.0~	506.0	240	335	760		370		2,800
Z33M471S	399.5~	540.5	250	350	810		385		2,600
Z33M561S	476.0~	644.0	300	420	970		425		2,200
Z33M681S	578.0~	782.0	365	510	1,175		460		1,800
Z33M821S	697.0~	943.0	440	615	1,415		580		1,500
Z33M102S	850.0~	1,150.0	520	730	1,725		620		1,000

## 寸 法

Z25M, Z33M型

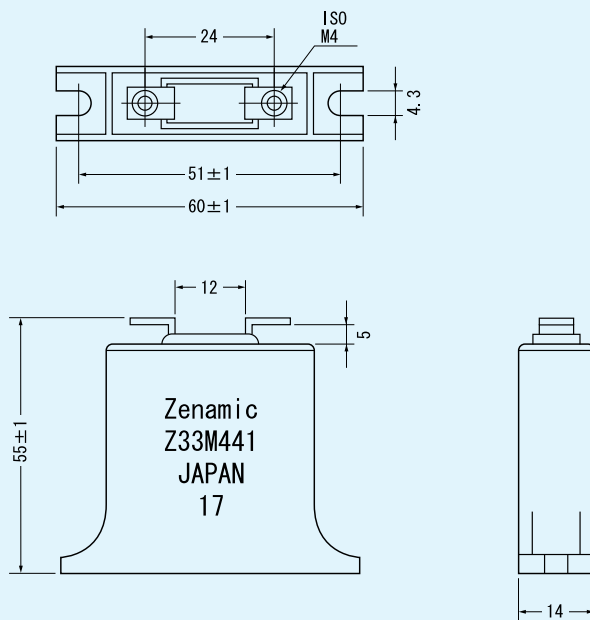

単位 [mm]

電圧-電流特性

Z25M221S~102S

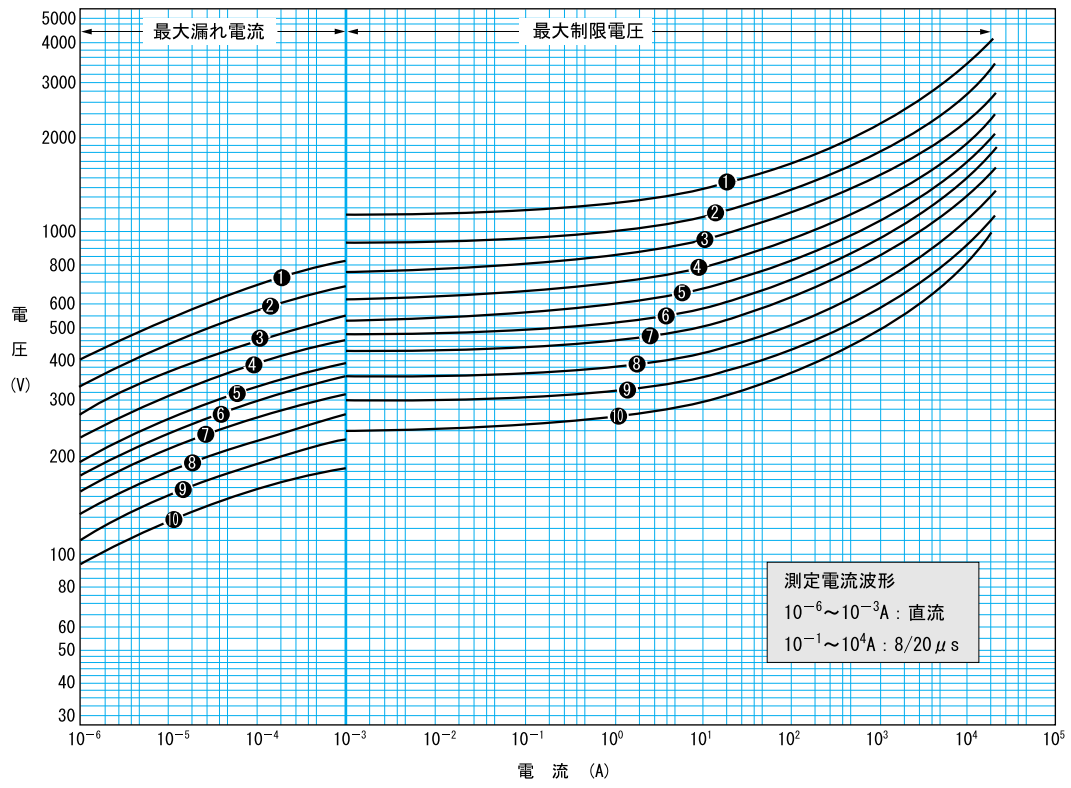

- ① Z25M102S
- ② Z25M821S
- ③ Z25M681S
- ④ Z25M561S
- ⑤ Z25M471S
- ⑥ Z25M441S
- ⑦ Z25M391S
- ⑧ Z25M331S
- ⑨ Z25M271S
- ⑩ Z25M221S

Z33M221S~102S

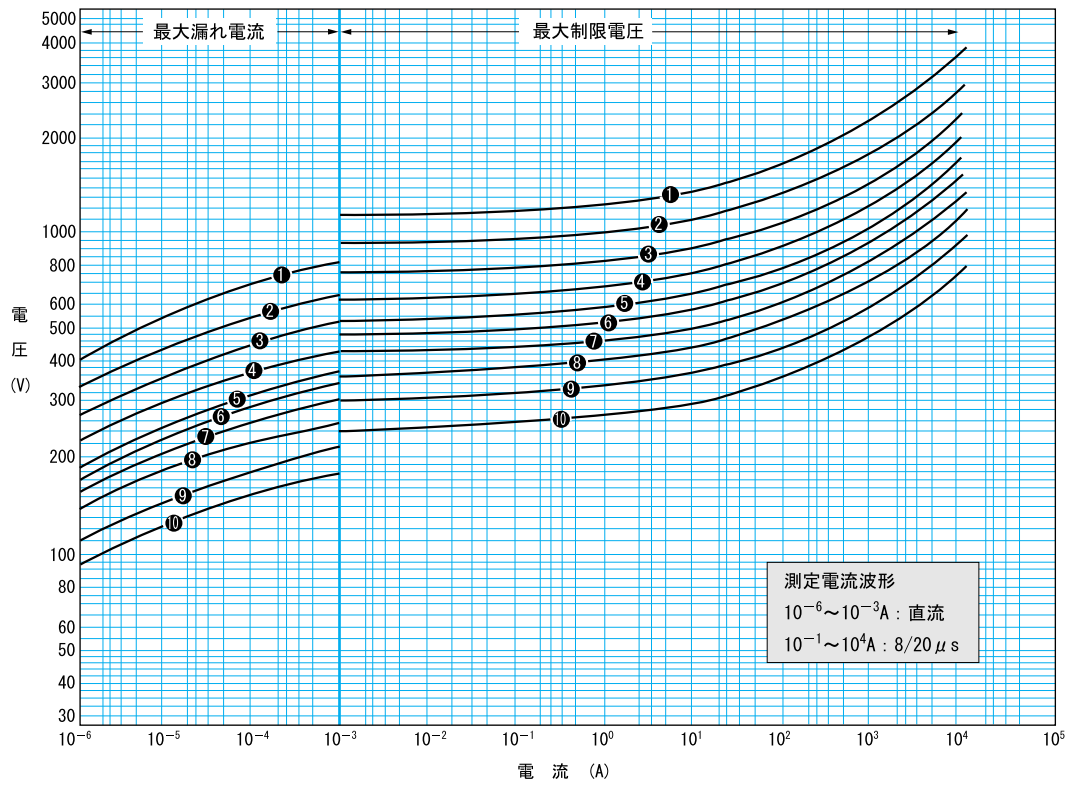

- ① Z33M102S
- ② Z33M821S
- ③ Z33M681S
- ④ Z33M561S
- ⑤ Z33M471S
- ⑥ Z33M441S
- ⑦ Z33M391S
- ⑧ Z33M331S
- ⑨ Z33M271S
- ⑩ Z33M221S

## サージ寿命特性

